

UNIVERSAL ACCESSORIES

Over the years Accessafe has designed a range of accessories able to solve problems which may occur during assembly or to complete the fencing systems with sensors and support components.

01. GASKETS

This accessory is used to cover mesh spikes which may occur when mesh is cut during assembly.

COMPATIBILITY

Framed and frameless guarding systems

02. BRACING

This accessory is used to guarantee stability and it is fitted to posts which carry heavy loads due to movable doors or posts which are positioned in difficult areas.

COMPATIBILITY

Framed and frameless guarding systems

03. ACCESSORIES FOR POST FIXING

This accessory is used to fit posts on irregular floors. This accessory is also used to fix posts on grids (max grid thickness 60 mm).

COMPATIBILITY

Framed and frameless guarding systems

04. CABLE TROUGH

This accessory is used to install cable troughs on Meta, Viteria or Modula posts.

COMPATIBILITY

Framed and frameless guarding systems

05. FLOOR RAILS

This accessory is complete with a floor rail and rollers for sliding doors.

COMPATIBILITY

Framed and frameless guarding systems

06. ROLLERS

This accessory is used to improve door opening. There are two types of kits: pivoting roller kit, free moving roller which rotates around vertical axle, or sliding roller kit, the roller moves on rails.

COMPATIBILITY

Framed and frameless guarding systems

07. HANDLES

Optional accessory for doors.

COMPATIBILITY

Framed and frameless guarding systems

01 GASKETS

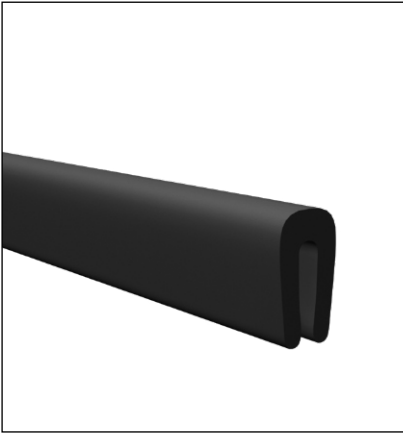

02 BRACING



03 ACCESSORIES FOR POST FIXING

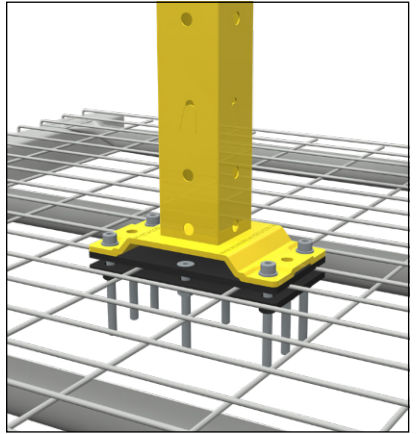

04 CABLE TROUGH



05 ROLLERS



06 FLOOR RAIL

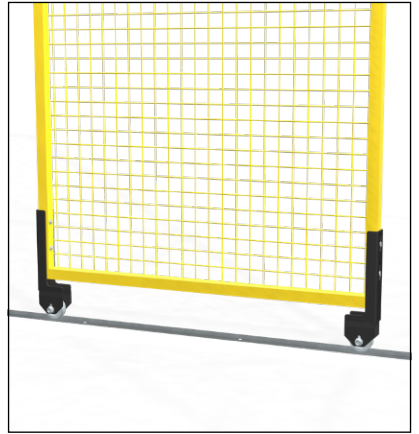

07 HANDLES

